

# Installation Instructions

## 1.2 PureTech 3 Channel Module



This product has been designed and manufactured to work correctly with installation as described in these instructions.

Failure to follow these instructions could result in damage to property, damage to the product and or potential injury.

It is very important that you read and understand these instructions thoroughly before installing this product.

### Included Contents:

- Tuning Module
- Wiring Loom
- Fastening Ties
- Installation and User instructions
- Protective Bag For Module – (prevents damage to unit casing)

### Before installation:

1. Open the vehicle's bonnet
2. Remove the ignition key
3. Close and lock the doors
4. Wait 5 minutes before removing any electrical plugs



Do not open the vehicle doors or unlock the vehicle while installation is in progress.

### Installation Location:

The module should be installed between the vehicle's MAP and Boost sensors as shown in the diagram.

### Locating the Unit:

The unit itself should be mounted away from:



Sources of Extreme Heat



Sources of Vibration



Sources of Spray Water

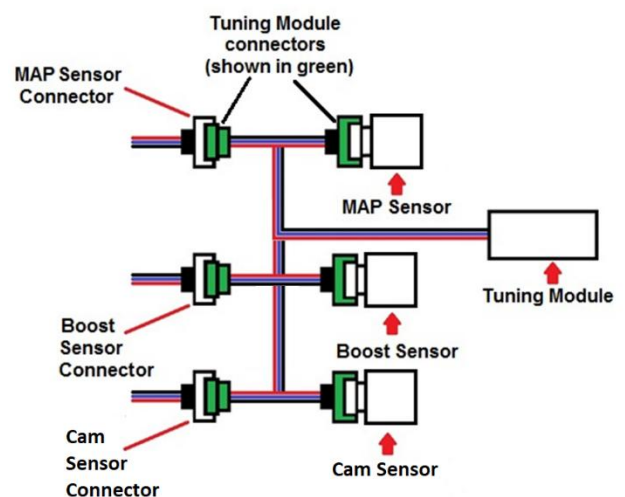

FCI3#(PT)-FCI4#(PT)-FCI3-PT3ch-843

# Installation Instructions

## 1.2 PureTech 3 Channel Module



### Introduction



- Ensure that your engine looks similar to the supplied photographs. (minor changes with ancillary components are to be expected, however if the engine looks nothing alike, please contact Bluespark Support. )
- Familiarise yourself with the locations of the connectors highlighted.
- Make sure that you have a good grasp of the operation of the connector clips and or locking tabs. - If the connectors you are trying to access are in an awkward place, it may be useful to try unplugging (and then re-inserting) a connector on the vehicle which is more easily accessible. Alternatively try plugging together the connectors on the Tuning Module itself.

# Installation Instructions

## 1.2 PureTech 3 Channel Module



### Step 1

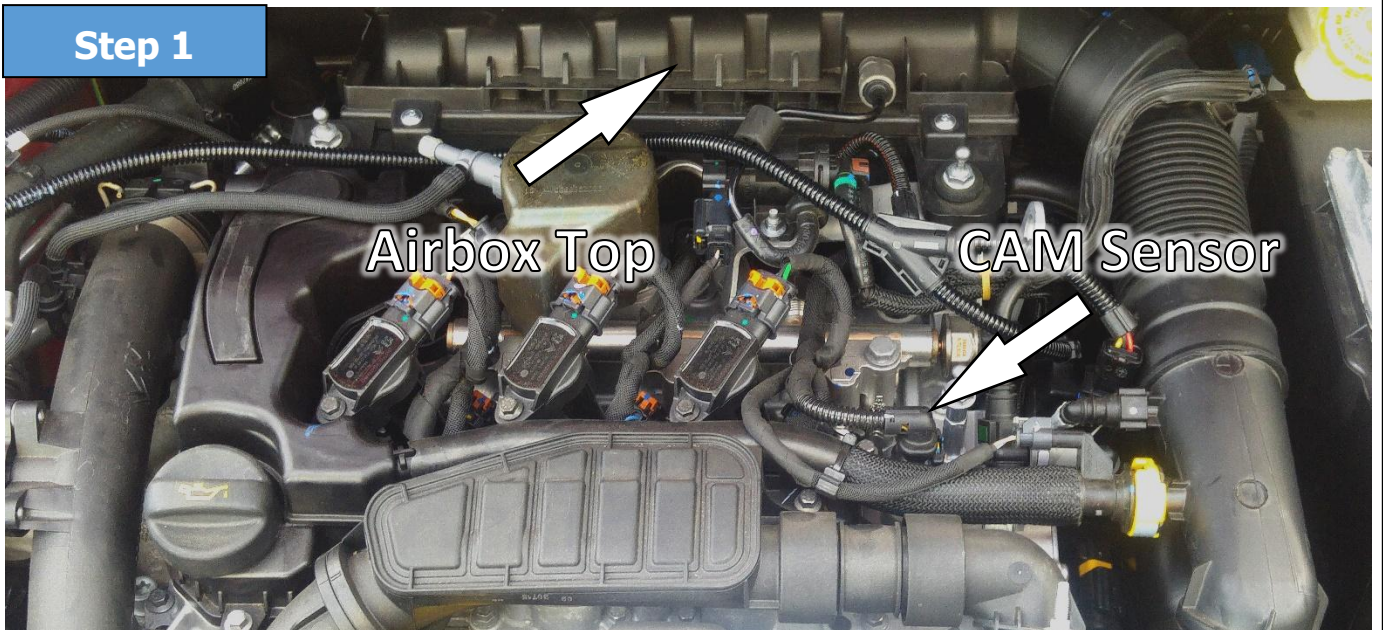

- Remove the engine cover. You should be left with an engine that looks similar to the above photo.

### Step 2.1

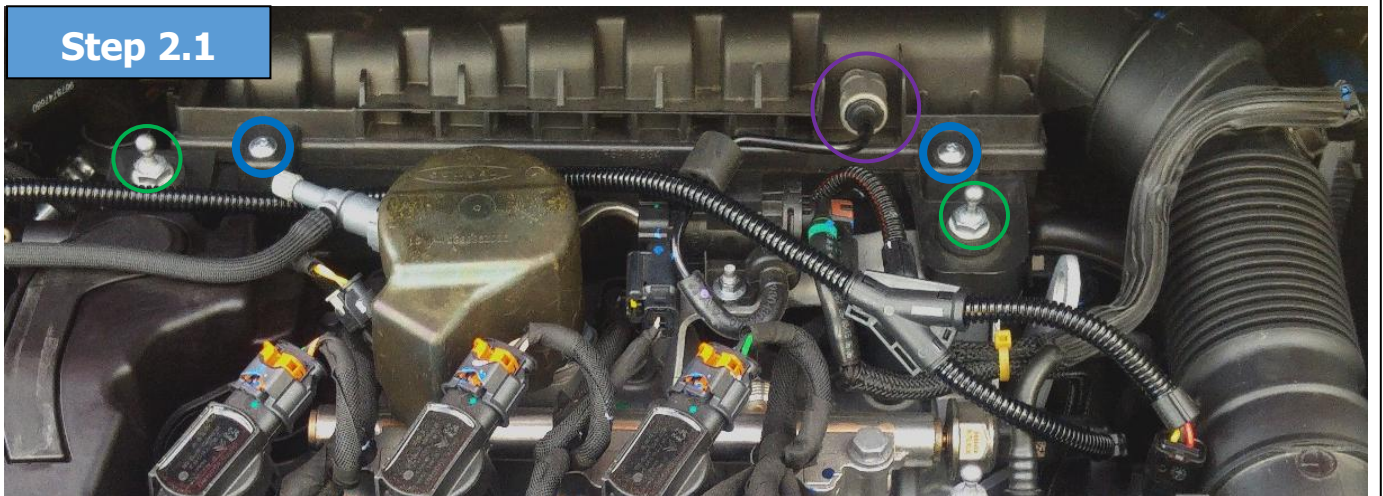

- Remove the bolts indicated in blue securing the airbox lid.
- Remove the hose marked in purple from the airbox lid. This has two tabs in its connector that must be pushed inwards to release.
- Remove the top lid of the airbox.

# Installation Instructions

## 1.2 PureTech 3 Channel Module



### Step 2.2



- To the left hand side of the Airbox lower there is a large breather hose held on with a metal spring clip.
- Remove the spring clip and remove the breather hose.

### Step 2.3

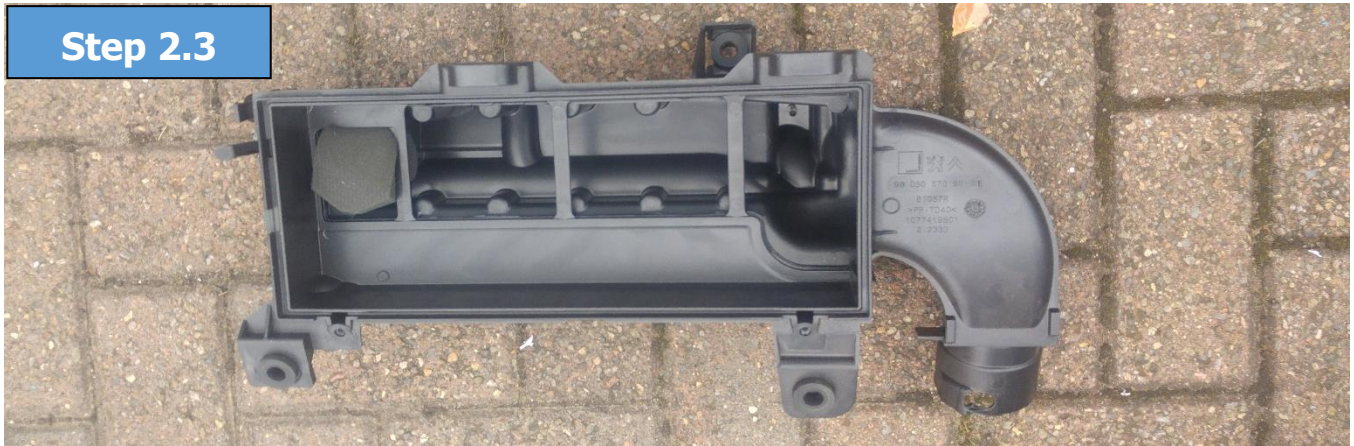

- Remove the bolts/engine cover mounts marked in green in step 2.1
- Remove the lower part of the airbox, disconnecting any ancillary pipes.

# Installation Instructions

## 1.2 PureTech 3 Channel Module



### Step 3

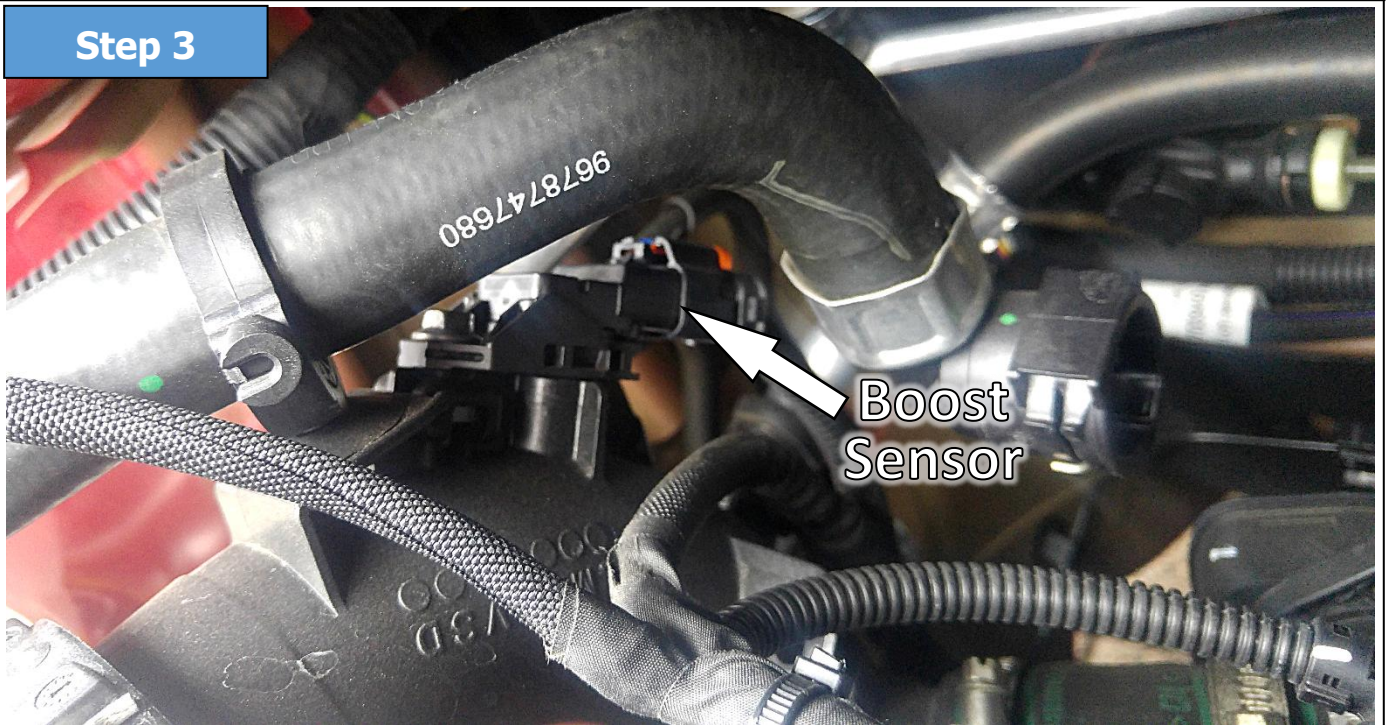

- Unplug the Boost Sensor connector (4 pin) by first pulling back the orange locking tab, then lifting up the clip and pulling back on the connector
- Insert the connector from the Tuning Module's wiring loom into the Boost Sensor.
- Insert the vehicle's Boost Sensor connector into the corresponding connector on the Tuning Module's wiring loom.

### Step 4



- Unplug the CAM Sensor connector (3 pin) by first pulling back the orange locking tab, then lifting up the clip and pulling back on the connector
- Insert the connector from the Tuning Module's wiring loom into the Boost Sensor.
- Insert the vehicle's CAM Sensor connector into the corresponding connector on the Tuning Module's wiring loom.

# Installation Instructions

## 1.2 PureTech 3 Channel Module



### Step 4

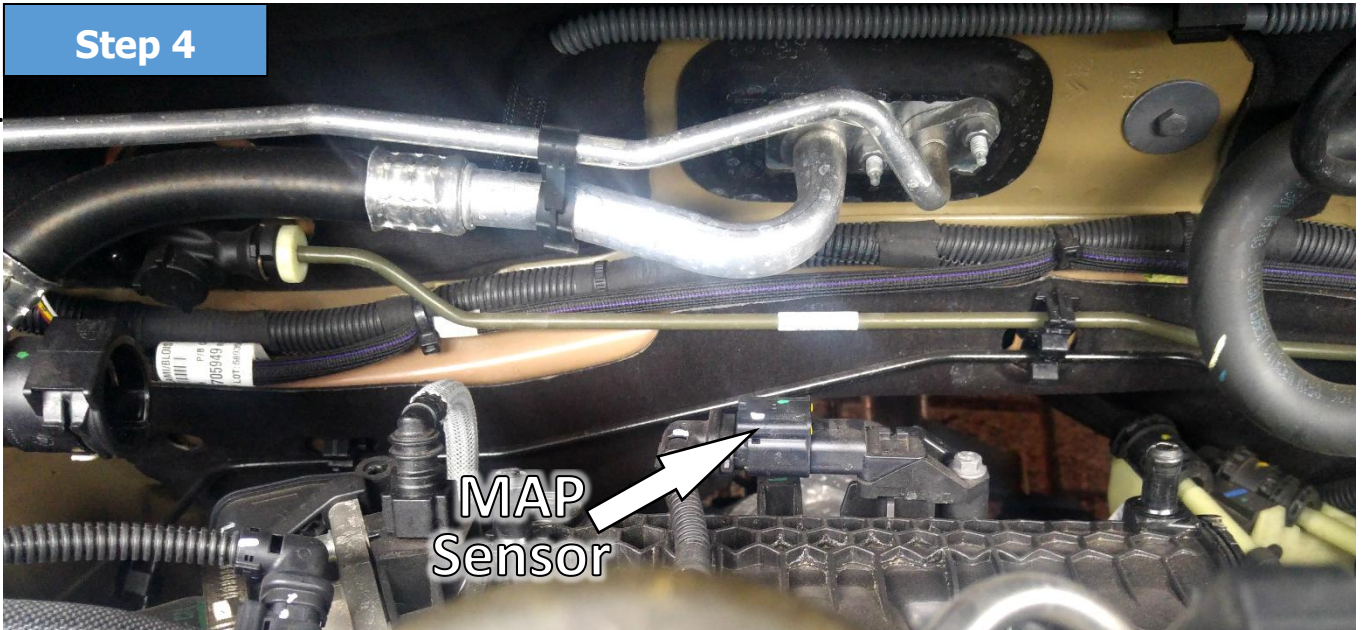

- Unplug the MAP Sensor connector (3 pin) by pressing down the yellow release tab inside and pulling back on the connector.
- Insert the connector from the Tuning Module's wiring loom into the MAP Sensor.
- Insert the Vehicle's MAP Sensor connector into the corresponding connector on the Tuning Module's wiring loom.

# Installation Instructions

## 1.2 PureTech 3 Channel Module



- Carefully re-install the engine cover/airbox.
- With the unit successfully installed please secure the unit and wiring loom within the engine bay, paying attention to the guidelines highlighted on Page 1.



**Route the tuning box wiring harness away from sources of heat (exhaust manifolds, EGR pipes, and most stainless steel pipes) and also away from any rotating parts such as belts.**

- Double check all connections are correct and firmly connected. If this is the case, start the vehicle and ensure there are no engine warning lights or error messages displayed.

If everything is as it should be, please feel free to take the vehicle out for a test drive and enjoy the added responsiveness and power added to your vehicle by the Tuning Module.