

Installation Instructions

Mercedes Benz 1.6/2.0 Petrol Engines



This product has been designed and manufactured to work correctly with installation as described in these instructions.

Failure to follow these instructions could result in damage to property, damage to the product and or potential injury.

It is very important that you read and understand these instructions thoroughly before installing this product.

Included Contents:

- Tuning Module
- Wiring Loom
- Fastening Ties
- Installation and User instructions
- Protective Bag For Module – (prevents damage to unit casing)



Before installation:

1. Open the vehicle's bonnet
2. Remove the ignition key
3. Close and lock the doors
4. Wait 5 minutes before removing any electrical plugs



Do not open the vehicle doors or unlock the vehicle while installation is in progress.

Installation Location:

The module should be installed between the vehicle's CAM, MAP and Boost sensors as shown in the diagram.

Locating the Unit:

The unit itself should be mounted away from:



Sources of Extreme Heat



Sources of Vibration



Sources of Spray Water

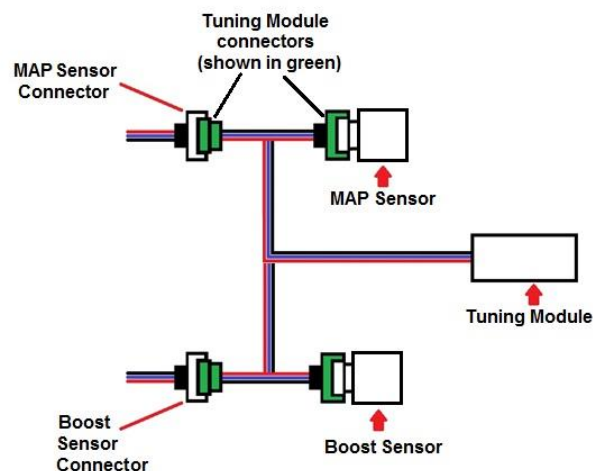

H3#-H3#-H3-3ch-789

Installation Instructions

Mercedes Benz 1.6/2.0 Petrol Engines

Bluespark
AUTOMOTIVE

Step 1

Plastic engine cover



- Remove the plastic engine cover by lifting it off the engine, then the engine should look similar to the photo in Step 2.

Installation Instructions

Mercedes Benz 1.6/2.0 Petrol Engines

Bluespark
AUTOMOTIVE

Step 2

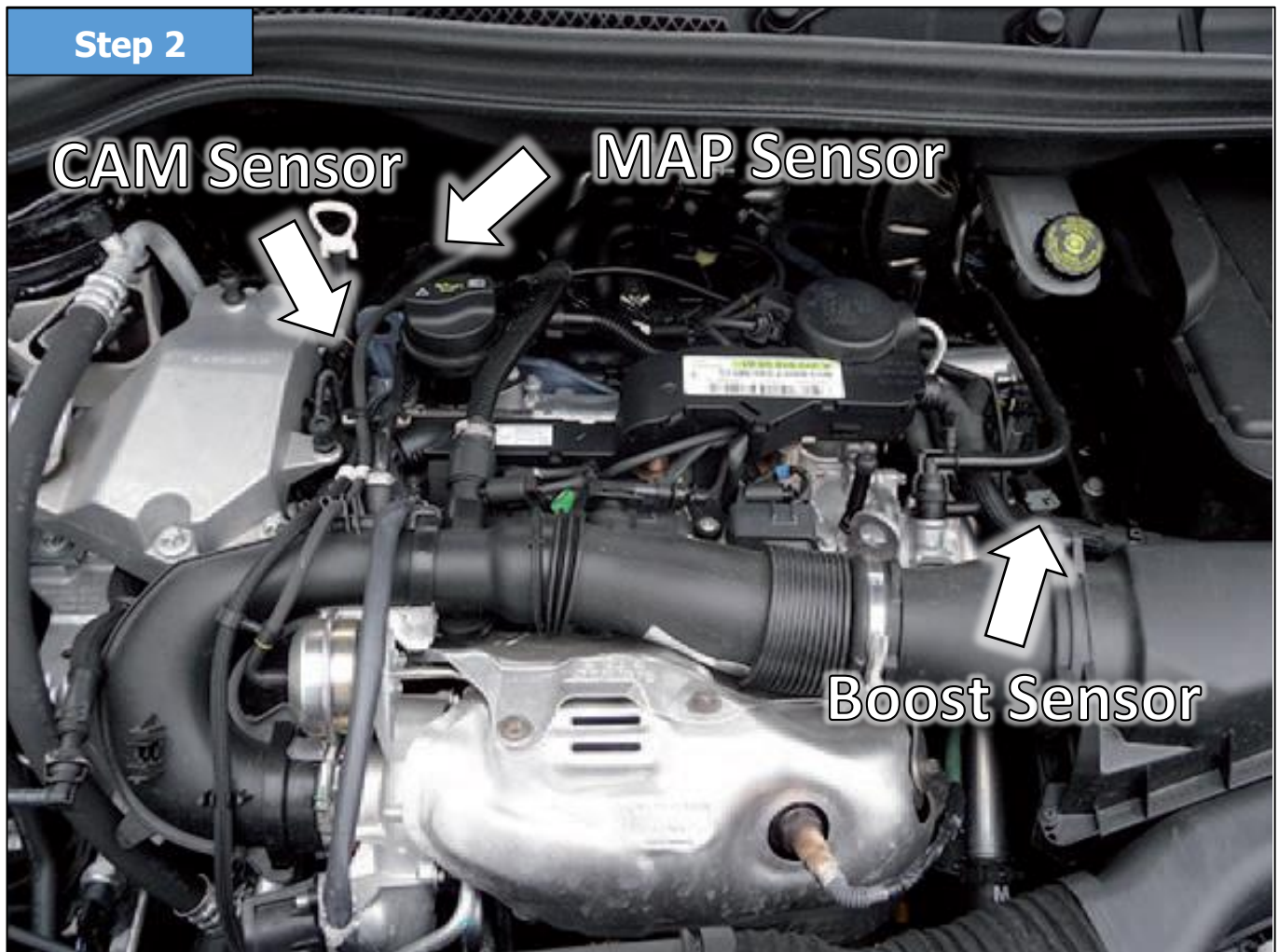

- Locate and familiarise yourself with the MAP and Boost sensors indicated in Step 2.

Installation Instructions

Mercedes Benz 1.6/2.0 Petrol Engines

Bluespark
AUTOMOTIVE

Step 3

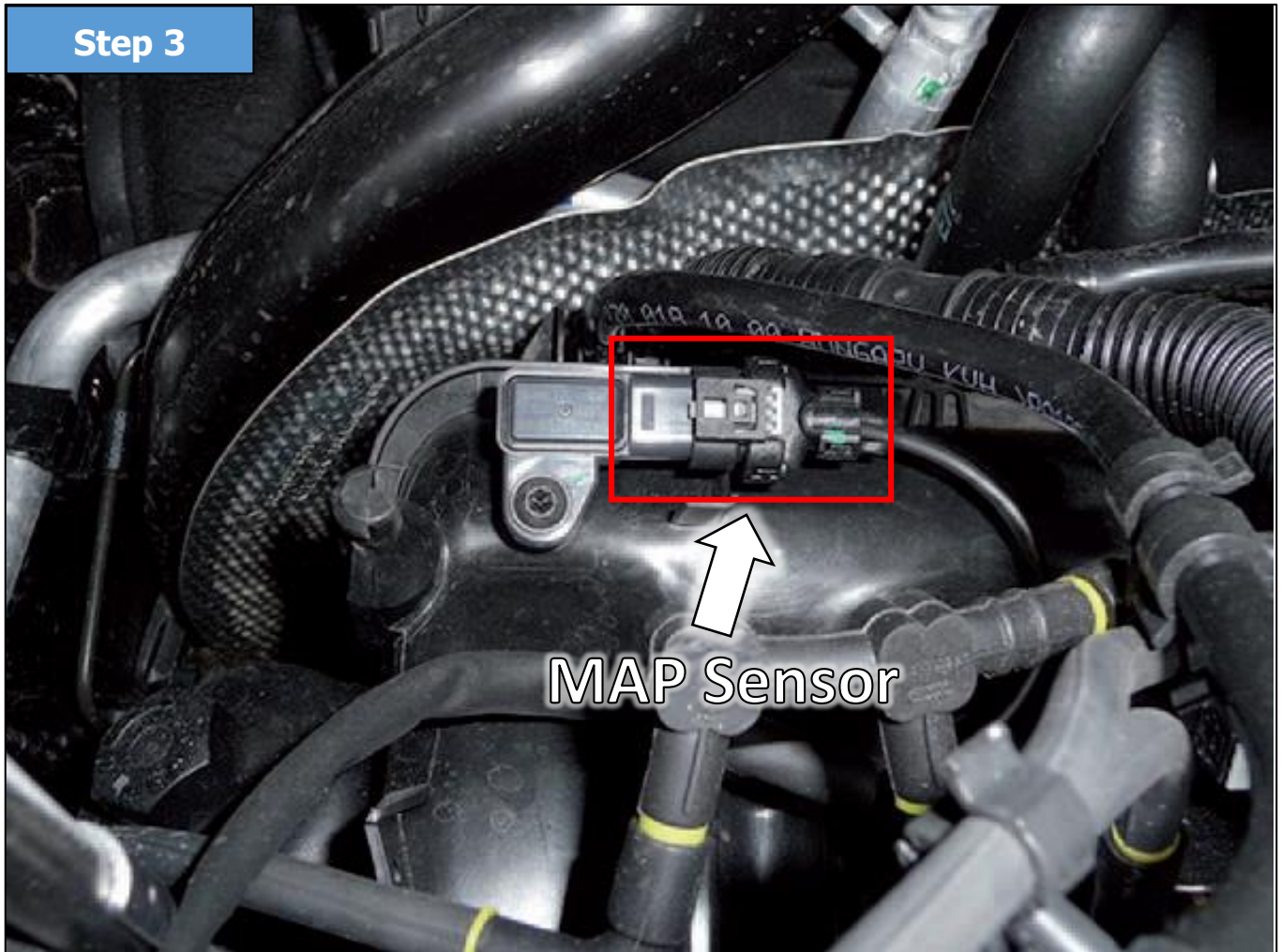

- Unplug the MAP Sensor connector (3 pin) by pulling back on the releasing tab, then press down the releasing tab and pull back on the connector.
- Insert the connector from the Tuning Module's wiring loom into the MAP Sensor.
- Insert the Vehicle's MAP Sensor connector into the corresponding connector on the Tuning Module's wiring loom.

Installation Instructions

Mercedes Benz 1.6/2.0 Petrol Engines

Bluespark
AUTOMOTIVE

Step 4

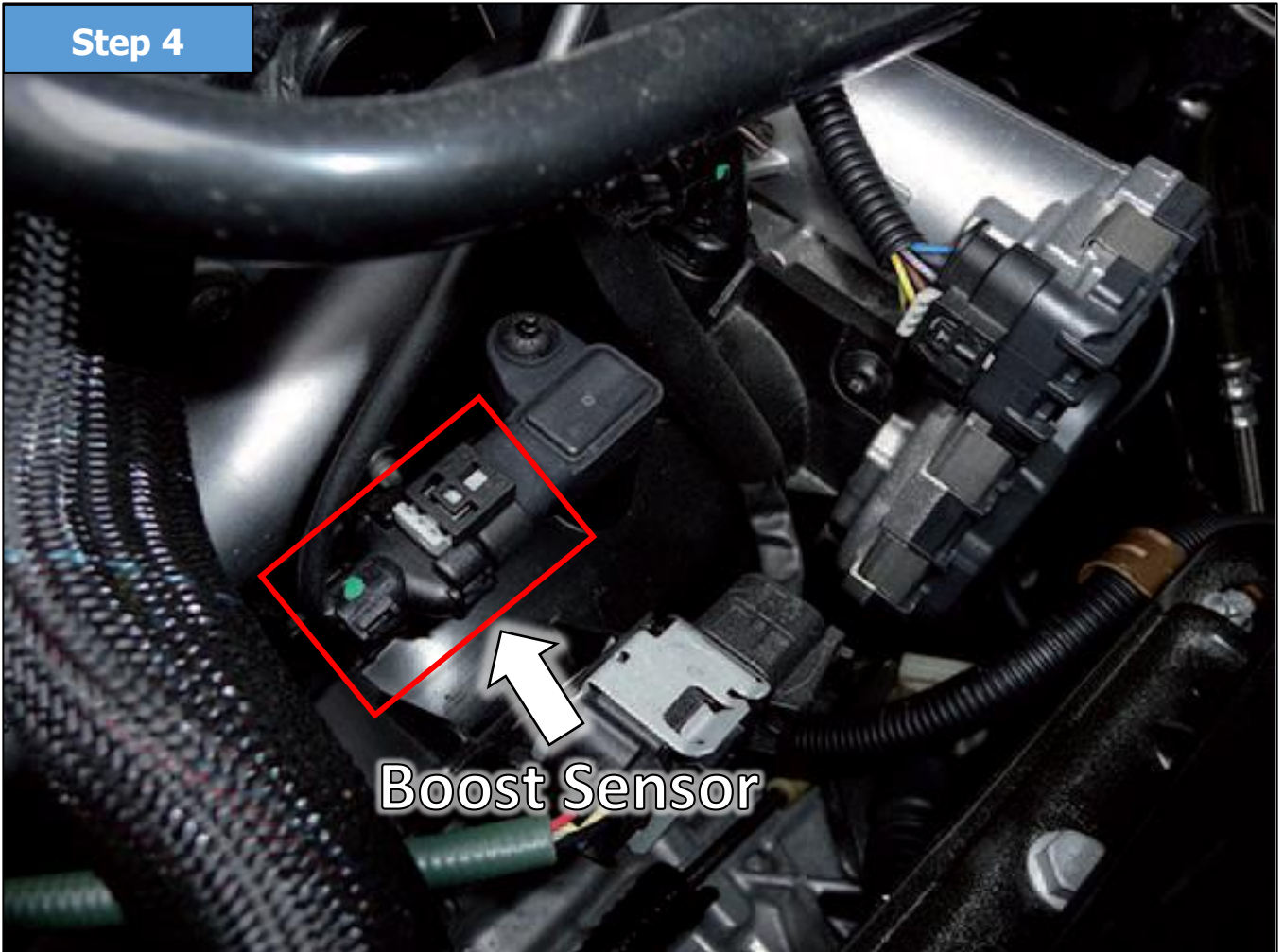

- Unplug the Boost Sensor connector (3 pin) by pulling back on the releasing tab, then press down the releasing tab and pull back on the connector.
- Insert the connector from the Tuning Module's wiring loom into the Boost Sensor.
- Insert the Vehicle's Boost Sensor connector into the corresponding connector on the Tuning Module's wiring loom.

Installation Instructions

Mercedes Benz 1.6/2.0 Petrol Engines

Bluespark
AUTOMOTIVE

Step 5

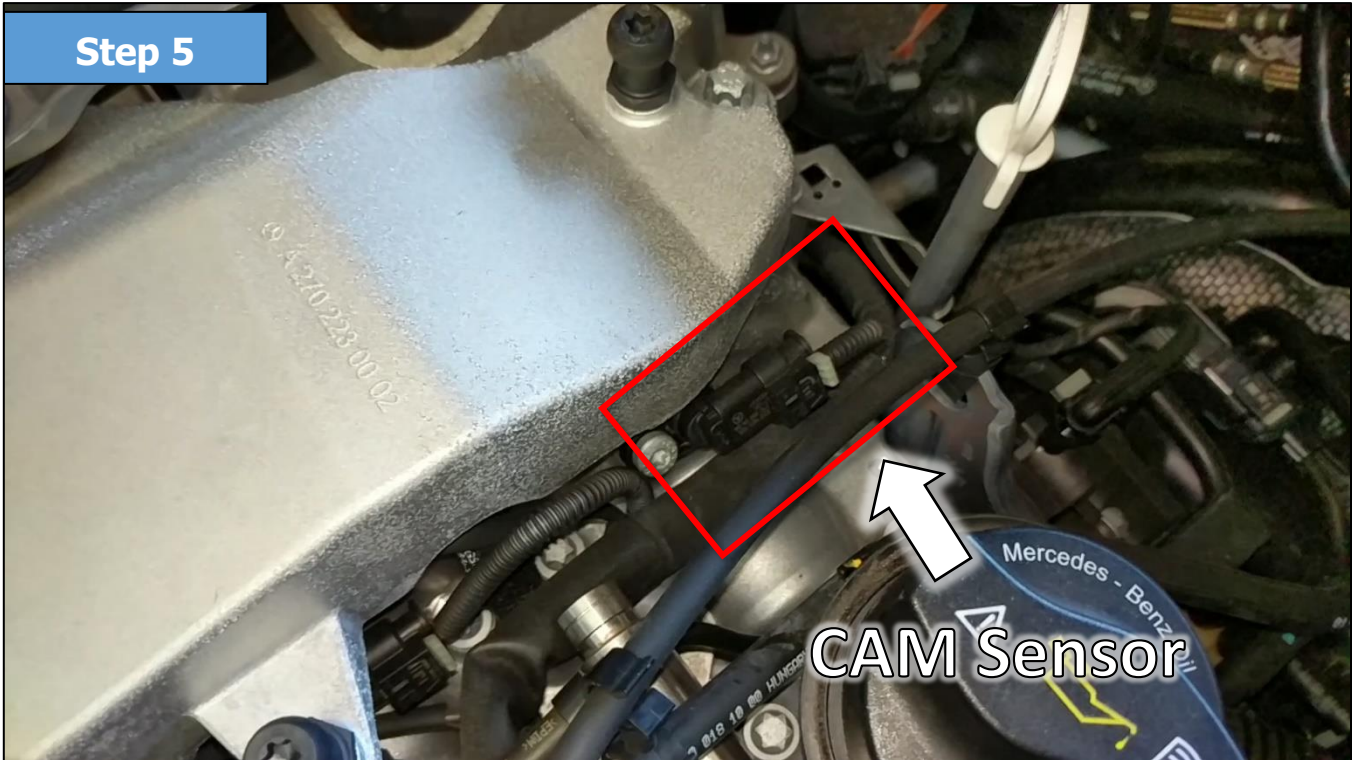

- Unplug the CAM Sensor connector (3 pin) by pulling back on the releasing tab, then press down the releasing tab and pull back on the connector.
- Insert the connector from the Tuning Module's wiring loom into the Boost Sensor.
- Insert the Vehicle's Boost Sensor connector into the corresponding connector on the Tuning Module's wiring loom.

Installation Instructions

Mercedes Benz 1.6/2.0 Petrol Engines

Bluespark
AUTOMOTIVE

Step 6

- With the unit successfully installed please secure the unit and wiring loom within the engine bay, paying attention to the guidelines highlighted on Page 1.



Route the tuning box wiring harness away from sources of heat (exhaust manifolds, EGR pipes, most stainless steel pipes) and also away from any rotating parts such as belts.

- Double check all connections are correct and firmly connected. If this is the case, start the vehicle and ensure there are no engine warning lights or error messages displayed.
- Re-install the undertray and place the engine cover back over the engine making sure it clips in to place.

If everything is as it should be, please feel free to take the vehicle out for a test drive and enjoy the added responsiveness and power added to your vehicle by the Tuning Module.