

Installation Instructions

Mazda 1.8 i-Art – Bluespark Pro + Boost



This product has been designed and manufactured to work correctly with installation as described in these instructions.

Failure to follow these instructions could result in damage to property, damage to the product and or potential injury.

It is very important that you read and understand these instructions thoroughly before installing this product.

Included Contents:

- Tuning Module
- Wiring Loom
- Fastening Ties
- Installation and User instructions
- Protective Bag for Module – (prevents damage to unit casing)

Before installation:

1. Open the vehicle's bonnet
2. Place the ignition key away from vehicle
3. Close all doors (do not re-open during install)
4. Wait 5 minutes to allow the ECU to power down before removing any electrical plugs.



Do not open the vehicle doors or unlock the vehicle while installation is in progress.

Installation Location:

The module should be installed between the vehicle's Rail Pressure and Boost Pressure sensors as shown in the diagram.

Locating the Unit:

The unit itself should be mounted away from:



Sources of Extreme Heat



Sources of Vibration



Sources of Spray Water

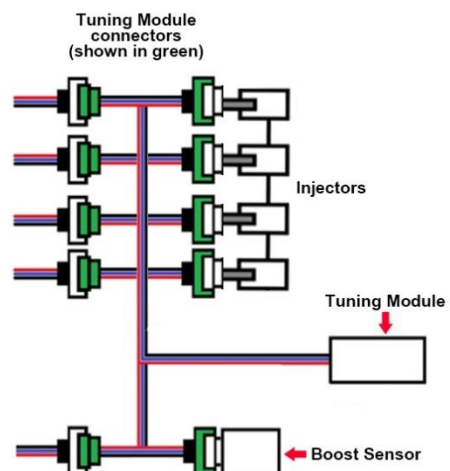

IART-Maz4-IART-235

Installation Instructions

Bluespark
AUTOMOTIVE

Mazda 1.8 i-Art – Bluespark Pro + Boost

Introduction



Introduction

- Ensure that your engine looks similar to the supplied photographs (minor changes with ancillary components are to be expected, however if the engine looks nothing alike, please contact Support.)
- Familiarise yourself with the locations of the connectors highlighted.
- Make sure that you have a good grasp of the operation of the connector clips and or locking tabs. - If the connectors you are trying to access are in an awkward place, it may be useful to try unplugging (and then re-inserting) a connector on the vehicle which is more easily accessible. Alternatively try plugging together the connectors on the Tuning Module itself.
- Remove the engine cover, this is held in place by 4 screws.

Installation Instructions

Mazda 1.8 i-Art – Bluespark Pro + Boost

Bluespark
AUTOMOTIVE

Step 1

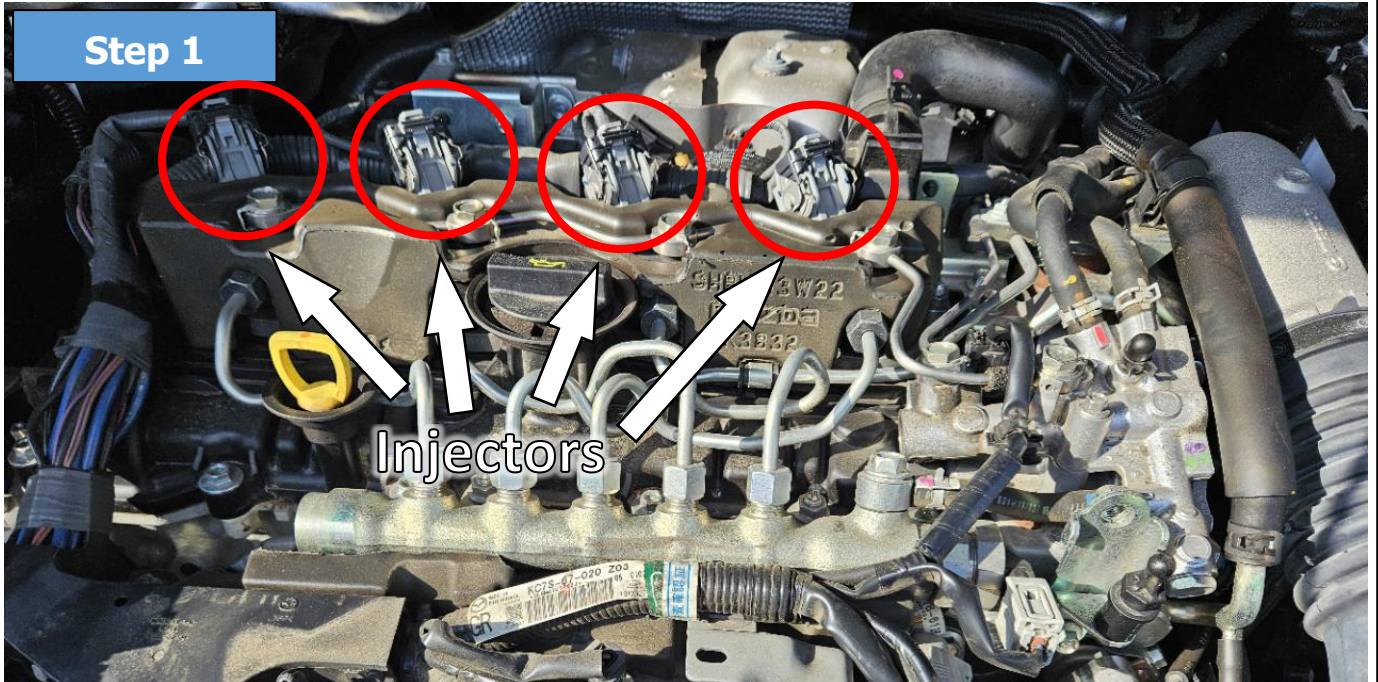

- This system plugs into each Injector. These are highlighted above.
- Disconnect each injector one at a time by pressing the release button and pivoting back the locking lever, this will slide the connector a little way off the injector. Then pull off the connector.

IMPORTANT

When connecting the loom, each connector pair on the wiring loom **MUST** be connected to a single injector and its original connector. The Injector plugs **MUST NOT** be crossed over, and must be re-fitted securely.

- Insert the connector from the Tuning Module's wiring loom onto each injector. Ensure the locking lever is pushed back into place. This will pull the connector fully onto the sensor.
- Insert each of the vehicle's injector connectors into the corresponding connector on the Tuning Module's wiring loom. Ensure the locking lever is pushed back into place. This will pull the connector fully onto the loom.

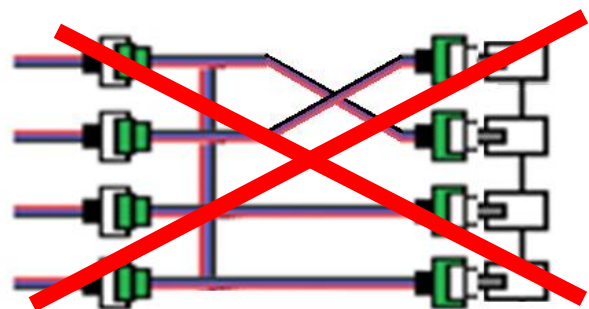

Installation Instructions



Mazda 1.8 i-Art – Bluespark Pro + Boost

Step 2



- Unplug the Boost Sensor connector (4 pin) by pressing down on the releasing tab and pulling back the connector.
- Insert the connector from the Tuning Module's wiring loom into the Boost Sensor.
- Insert the Vehicle's Boost Sensor connector into the corresponding connector on the Tuning Module's wiring loom.

- With the unit successfully installed please secure the unit and wiring loom within the engine bay, paying attention to the guidelines highlighted on Page 1.



Route the tuning box wiring harness away from sources of heat (exhaust manifolds, EGR pipes, most stainless steel pipes) and also away from any rotating parts such as belts.

- Double check all connections are correct and firmly connected. If this is the case, start the vehicle and ensure there are no engine warning lights or error messages displayed.

If everything is as it should be, please feel free to take the vehicle out for a test drive and enjoy the added responsiveness and power added to your vehicle by the Tuning Module.