

Installation Instructions



Ford Ranger 2.2 3.2 TDCi Engines

C.R. Tech and Bluespark Pro Diesel Tuning Boxes.

BEFORE STARTING INSTALLATION ENSURE IGNITION IS SWITCHED OFF AND KEYS ARE REMOVED FROM THE IGNITION!

General system layout:

The Tuning box unit should be installed between the vehicle's rail pressure sensor and the connector which attaches to this. The diagrams below illustrate the fitment:

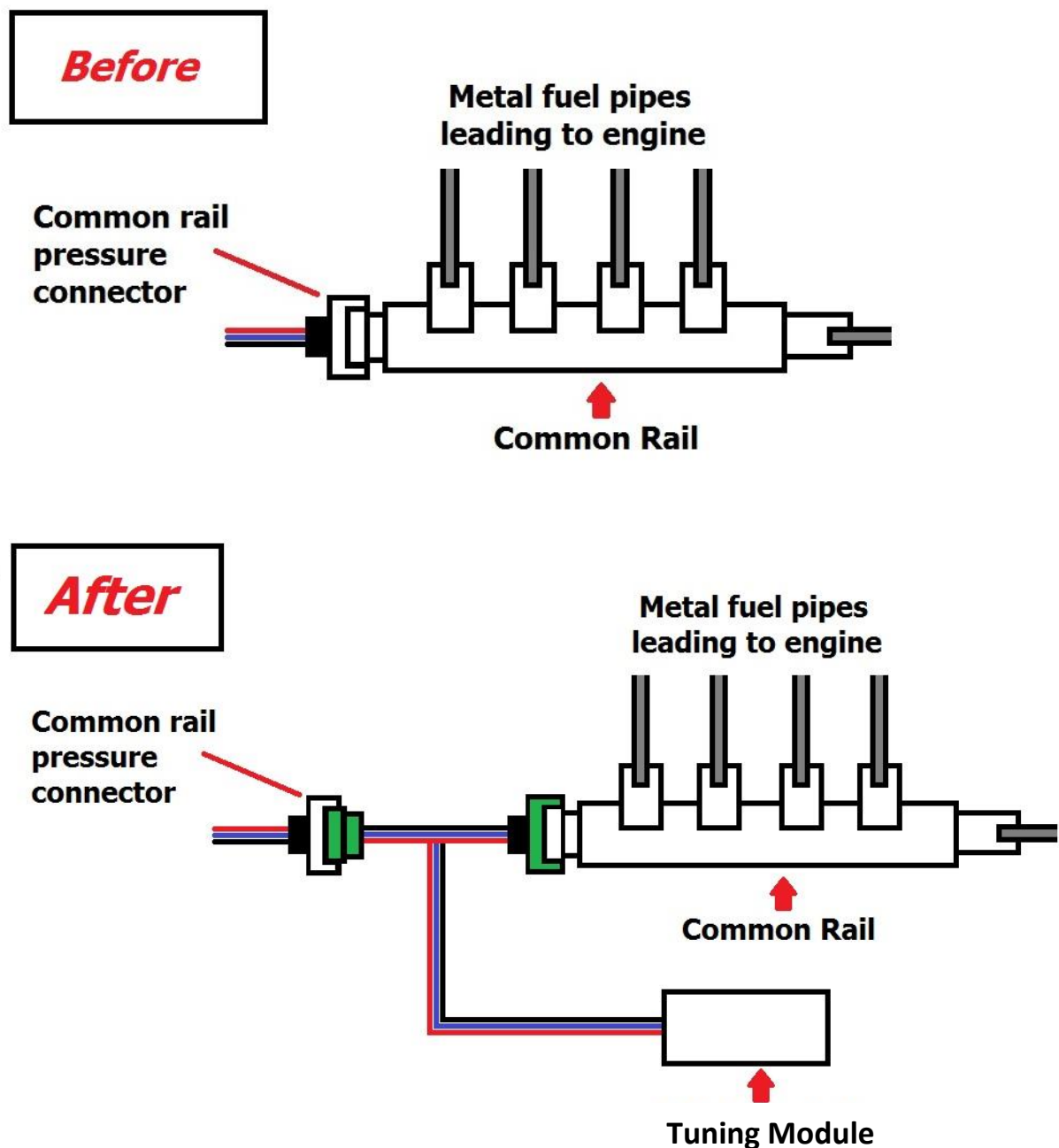

Step 1.

Remove the plastic engine cover and locate the common rail as shown in the image below:



Step 2.

Locate the rail pressure sensor on the end of the rail.



- Attach the plug from the Tuning module to the rail pressure sensor
- Attach the connector that you have removed from the rail pressure sensor to the remaining connector on the Tuning module.

Refer to the next page for a system check. Once complete you can refit any components removed from your vehicle.

Enjoy improved power and fuel economy from your vehicle!